

RoHS Compliant

Rev	Modification	Date
A1	Issue	07/13/2016



Key Features:

- High Speed USB 2.0 B Female to A Female Panel Mount Adapter
- The screw design helps to connect the device tightly
- Convenient way to combine two USB cables through a panel without any signal loss
- Designed to support USB 2.0 communication and features, including data transfer rate up to 480Mbps
- Backward compliant with full-speed USB 1.1 (12 Mbps) and low speed USB 1.0 (1.5 Mbps)
- 2 Years Warranty

Projection: 	Tolerance: XX= XXX=	Product: USB 2.0 AF/BF Panel Mount Adapter
Scale: None	DWG No.: PM6001	Part No.: UMPM6001
Unit: mm	Page: 1/2	Customer:
Customer Approve:		UMA Technology Co., Ltd Tel: 0086 574 8704 2335 Fax: 0086 574 5687 7589 Email: info@umateck.com Web: www.umateck.com Add: 4-1, Shanghai Fortune building, South Dongyi Rd, Zhenhai District, Ningbo, China, 315202
Approve:	Dell Zheng	
Check:	Kelly Xu	
Draw:	David Han	



RoHS Compliant

Rev	Modification	Date
A1	Issue	07/13/2016

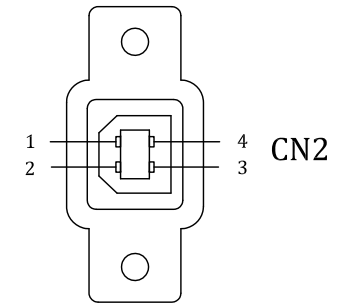
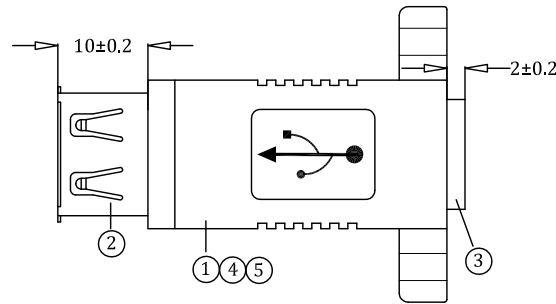
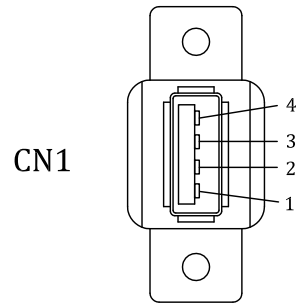

Electronic Tests:

- A. Open/Short/Intermittence: 100%
- B. Hi-Pot: AC 300V 0.01S 1mA
- C. Insulation Resistance: DC 300V 5MΩ Min
- D. Conductive Resistance: 3Ω Max

PIN OUT

CN1	CN2
1	1
2	2
3	3
4	4
Shell	Shell

					Projection:	Tolerance: XX= XXX=	Product: USB 2.0 AF/BF Panel Mount Adapter
⑤	Outer Mold	45P PVC, Black	4	g	Scale: None	DWG No.: PM6001	Part No.: UMPM6001
④	Inner Mold	LDPE	2	g	Unit: mm	Page: 2/2	Customer:
③	Connector	USB 2.0 B Female, PIN Gold Flash, Shell Nickel Plated	1	pc	Customer Approve:		UMA Technology Co., Ltd Tel: 0086 574 8704 2335 Fax: 0086 574 5687 7589 Email: info@umateck.com Web: www.umateck.com Add: 4-1, Shanghai Fortune building, South Dongyi Rd, Zhenhai District, Ningbo, China, 315202
②	Connector	USB 2.0 A Female, PIN Gold Flash, Shell Nickel Plated	1	pc	Approve:	Dell Zheng	
①	Cable	UL1007 28AWG*5C, 20mm	20	mm	Check:	Kelly Xu	
No.	P/No.	Specifications	Q'TY	Unit	Draw:	David Han	

